

INSTRUCTION MANUAL

EURO CHARGER II-VHO

AUTOMATIC BATTERY CHARGER



MODEL # O91-143-XX

NOTE :

This charger is designed for vehicles with dual electrical systems,
Each battery is individually charged

3 YEAR WARRANTY

KUSSMAUL ELECTRONICS CO., INC.

170 CHERRY AVE., WEST SAYVILLE, N.Y. 11796

1

INTRODUCTION

The Euro Charger II-VHO, Model 091-143-xx is a compact, completely automatic dual channel battery charger designed specifically for the fire service and emergency vehicles. The voltage of each battery is individually controlled so that each battery is charged only as much as required. Once the batteries are fully charged, current stops flowing to guard against overcharging and water boil-off. Of rugged construction, the charger is made to withstand the shock and vibration normally encountered by vehicle mounted equipment. Utilizing components which meet international safety requirements makes this charger ideal for worldwide applications.

BATTERY CHARGER FEATURES

Completely automatic operation, charges battery on demand
Input voltage, switch selectable, 115 volt or 230 volt
output voltage regulated, eliminates overcharging battery
Output, current limited to protect charger from overloading
Optional charge indicators

INSTALLATION

The Euro Charger II-VHO Automatic Battery Charger should be installed in an area with adequate ventilation.

1. Mount the charger using the four holes provided for this.
2. Connect the wiring from the batteries to the Output Terminal Strip.
3. Double check all wiring before proceeding. Verify that battery voltage appears at charger output terminals.
4. Set the voltage selector to either the 115 volt or 230 volt position to match the input source available.
5. Connect the input power to the input power terminal strip and energize charger.
7. Verify that power indicator is illuminated and charger is charging.

INSTALLATION WIRING DIAGRAM

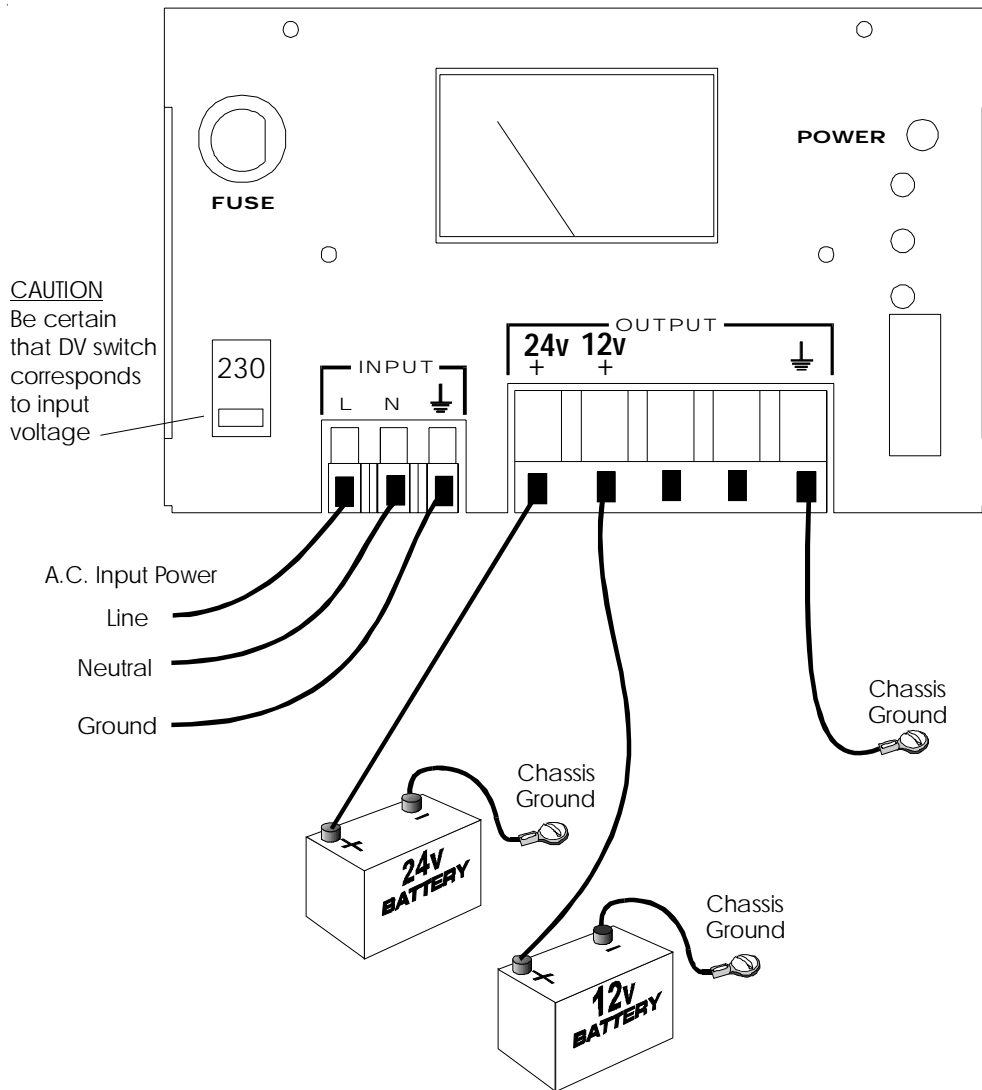

IMPORTANT: Charger output wire size is 12 awg. Wire size is for a maximum length of 20 feet. If wiring is to be longer, larger wiring is required. Additional information is available on request.

SPECIFICATION & OUTLINE

SPECIFICATIONS:

- Output:** see chart
- Output Current:** see chart
- Charge Indicator:** 0-50 amps
- Weight:** 22 lbs

Model #	Output Current	Output Voltage	Input Voltage	Input Current	Input Fuse	Charge Indicator
091-143-12	40 Amps	12	230/115, 50/60 HZ	5/10 Amps	12 Amp. (F)	50 amps
091-143-24	20 Amps	24	230/115, 50/60 Hz	5/10 Amps	12 Amp. (F)	25 amps

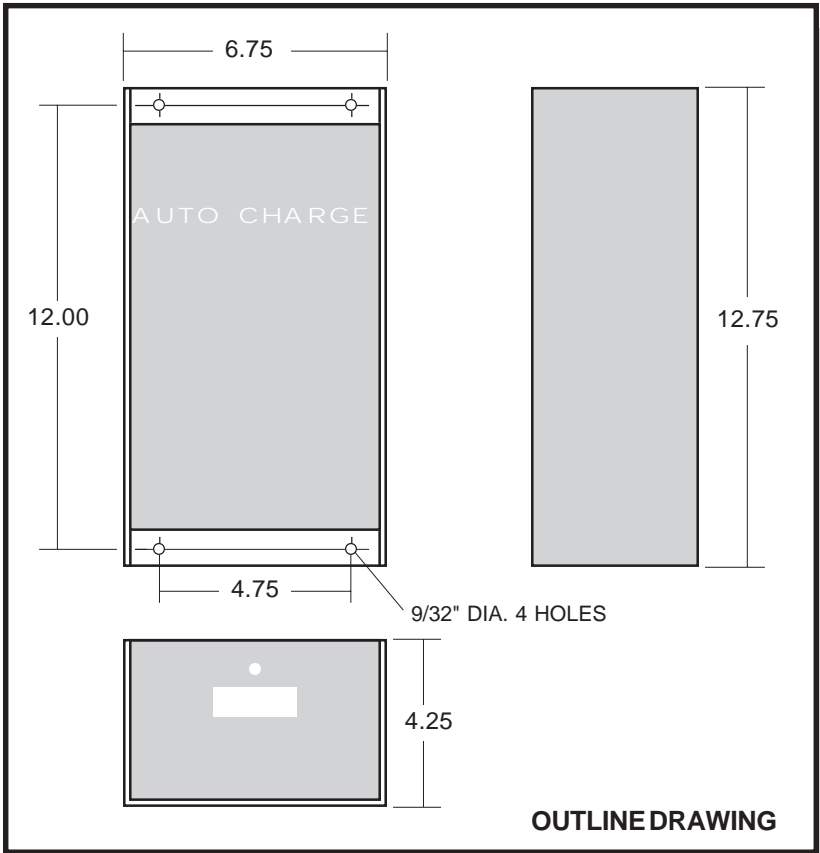

INSTALLATION RECORD & WARRANTY

Date Installed _____

Installed By _____

Vehicle Identification _____

Vehicle Owner _____

WARRANTY

All products of Kussmal Electronics Company Inc. are warranted to be free of defects of material or workmanship. Liability is limited to repairing or replacing at our factory, without charge, any material or defects which become apparent in normal use within 3 years from the date the equipment was shipped. Equipment is to be returned, shipping charges prepaid and will be returned, after repair, shipping charges paid.

Kussmal Electronics Company, Inc. shall have no liability for damages of any kind to associated equipment arising from the installation and /or use of the Kussmal Electronics Company, Inc. products. The purchaser, by the acceptance of the equipment, assumes all liability for any damages which may result from its installation, use or misuse, by the purchaser, his or its employees or others.