

INSTRUCTION MANUAL

---

# EURO CHARGER I-VHO

## AUTOMATIC BATTERY CHARGER



MODEL #091-162-XX  
FOR SINGLE BATTERY SYSTEMS

**3 YEAR WARRANTY**

---

**KUSSMAUL ELECTRONICS CO., INC.**  
170 CHERRY AVE., WEST SAYVILLE, N.Y. 11796

# INTRODUCTION

---

The Euro Charger I -VHO Battery Charger is a compact completely automatic charger designed for installation on vehicles with a single 12Volt or 24Volt battery system. Voltage is sensed so that the battery system is charged according to its requirements.

The total output of the Euro Charger I -VHO Battery Charger is:

091-162-24: 20 Amperes for 24Volt Battery Systems

091-162-12: 40 Amperes for 12Volt Battery Systems

Construction of the Euro Charger I -VHO is extremely rugged to withstand the shock and vibration normally encountered by vehicle mounted equipment. The unit operates completely automatically and stops charging the battery system when fully charged. There is no trickle charge and therefore no danger of overcharging and water boil-off. Any parasitic loads on the battery such as radio, lights, etc., are automatically supplied with current by the charger.

# INSTALLATION

---

The Euro Charger I -VHO Automatic Battery Charger should be installed in an area with adequate ventilation.

1. Mount the charger using the four holes provided for this.
2. Connect the wiring from the battery system to the Output Terminal Strip.
3. Connect the wiring to the battery system. Ring lugs that have been securely crimped, or soldered, should be used.
4. Double check all wiring before proceeding.
5. Verify that the dual voltage switch (DV switch) on the front panel corresponds to the applied voltage.
6. Wire the A.C. power to power input terminal strip.
7. Pilot light will light to show that the charger has power.

# INSTALLATION WIRING DIAGRAM

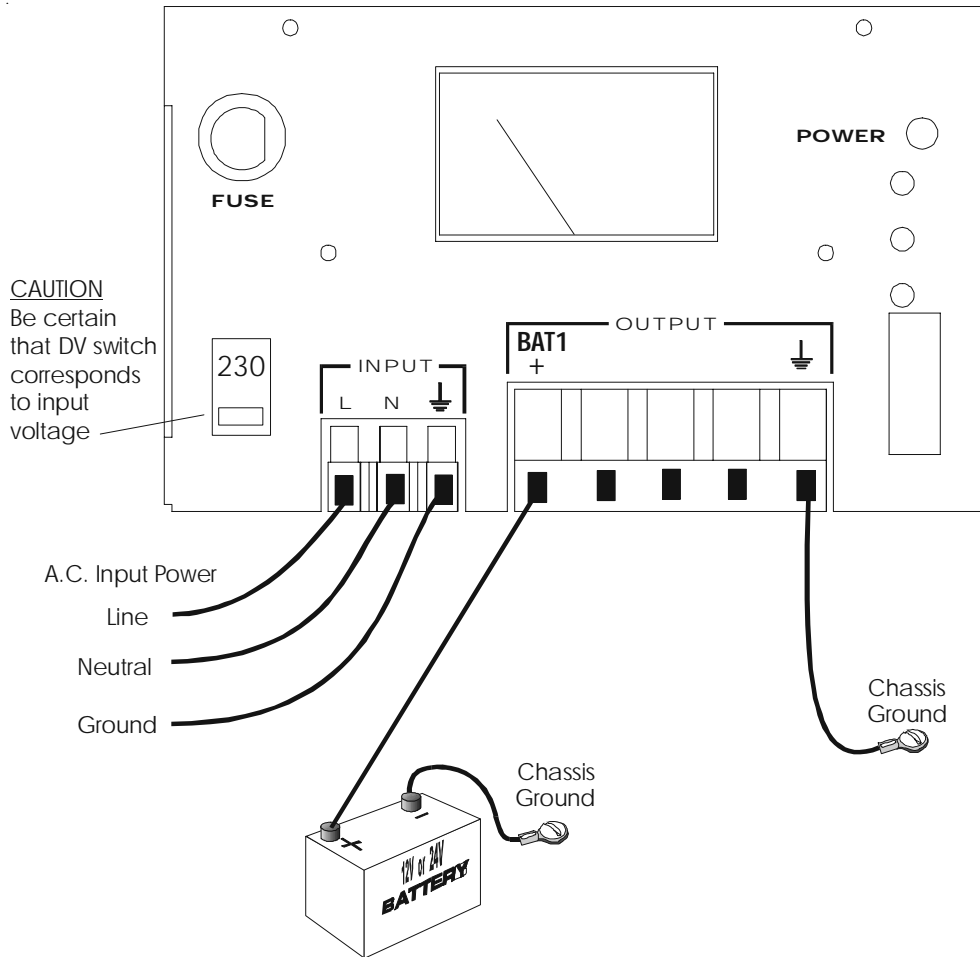

**IMPORTANT:** Charger output wire size is AWG #8, minimum. Wire size is for a maximum length of 20 feet. If wiring is to be longer, larger wiring is required. Additional information is available on request.

# SPECIFICATION & OUTLINE

## SPECIFICATIONS:

**Input fuse:** 12 Amperes

**Output Voltage:** See Chart

**Output Current:** See Chart

**Charge Indicator:** See Chart

**Weight:** 22 lbs

Model#	Output Current	Output Voltage	Input Voltage	Input Current	Charge Indicator
091-162-12	40 Amps	12V	230/115, 50/60 Hz	5.0/10.0 Amps	50 Amps
091-162-24	20 Amps	24V	230/115, 50/60 Hz	5.0/10.0 Amps	25 Amps

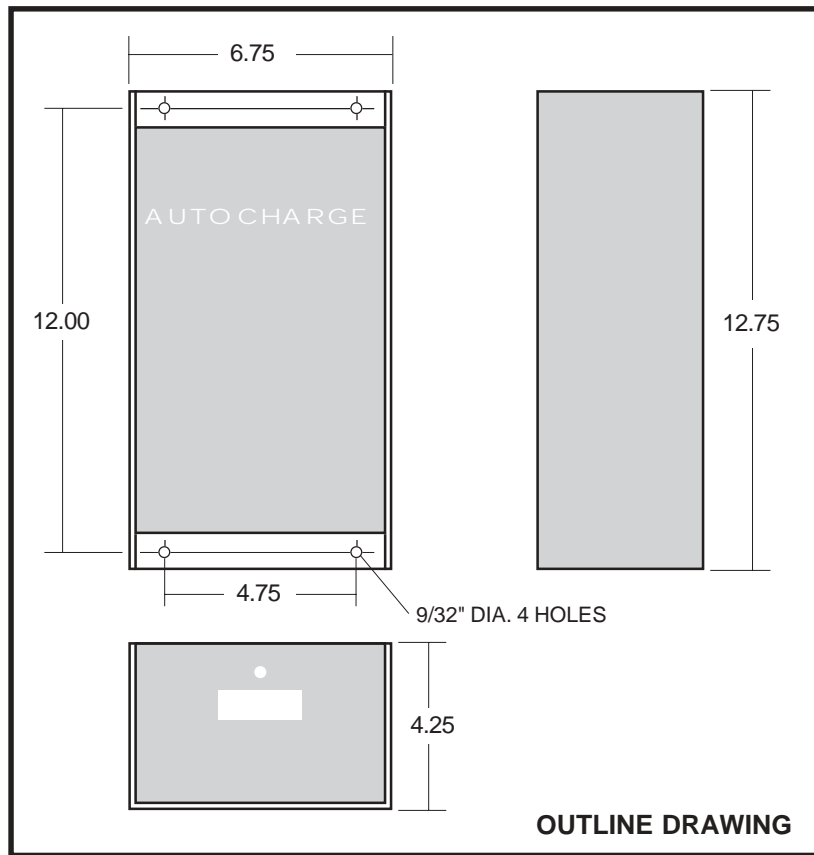

# INSTALLATION RECORD & WARRANTY

---

Date Installed \_\_\_\_\_

Installed By \_\_\_\_\_

Vehicle Identification \_\_\_\_\_

Vehicle Owner \_\_\_\_\_

## WARRANTY

All products of Kussmal Electronics Company Inc. are warranted to be free of defects of material or workmanship. Liability is limited to repairing or replacing at our factory, without charge, any material or defects which become apparent in normal use within 3 years from the date the equipment was shipped. Equipment is to be returned, shipping charges prepaid and will be returned, after repair, shipping charges paid.

Kussmal Electronics Company, Inc. shall have no liability for damages of any kind to associated equipment arising from the installation and /or use of the Kussmal Electronics Company, Inc. products. The purchaser, by the acceptance of the equipment, assumes all liability for any damages which may result from its installation, use or misuse, by the purchaser, his or its employees or others.